

AQUALUX Series Domestic Hot Water Heat Pump



**A new
generation in
hot water**

CALL:1800302050
sales@wilsonheatpumps.com.au
www.wilsonheatpumps.com.au

Discover the Wilson Difference

For over 90 years Wilson Hot Water has been designing and manufacturing hot water systems in Melbourne.



Wilson is a local business which has always been at the forefront of products designed and engineered with the Australian climate in mind. Our latest innovation brings together a team with years of experience in both heat pump and hot water technology.

The Wilson Aqualux Heat Pump offers unparalleled efficiency, reliability, and sustainability.



Why Heat Pumps?

Save up to 78% on energy costs compared to traditional hot water.

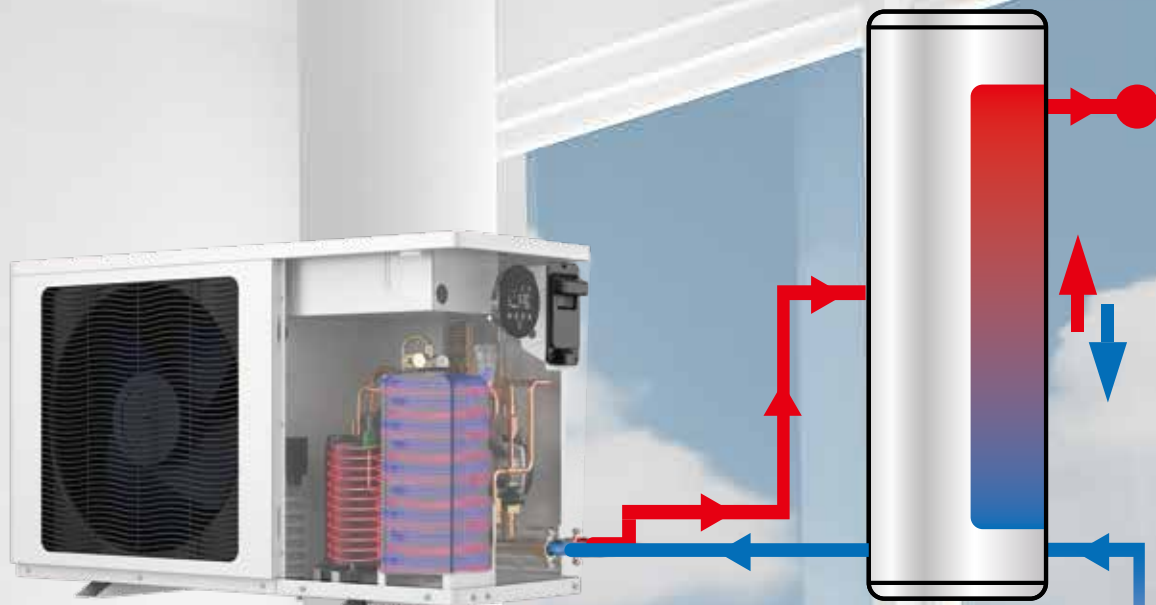

Proven to save money and help the environment

Research undertaken by Sustainability Victoria concluded: Running costs for heat pumps are significantly lower than other forms of heating. Greenhouse emissions are considerably lower than any other form of hot water heating technologies.

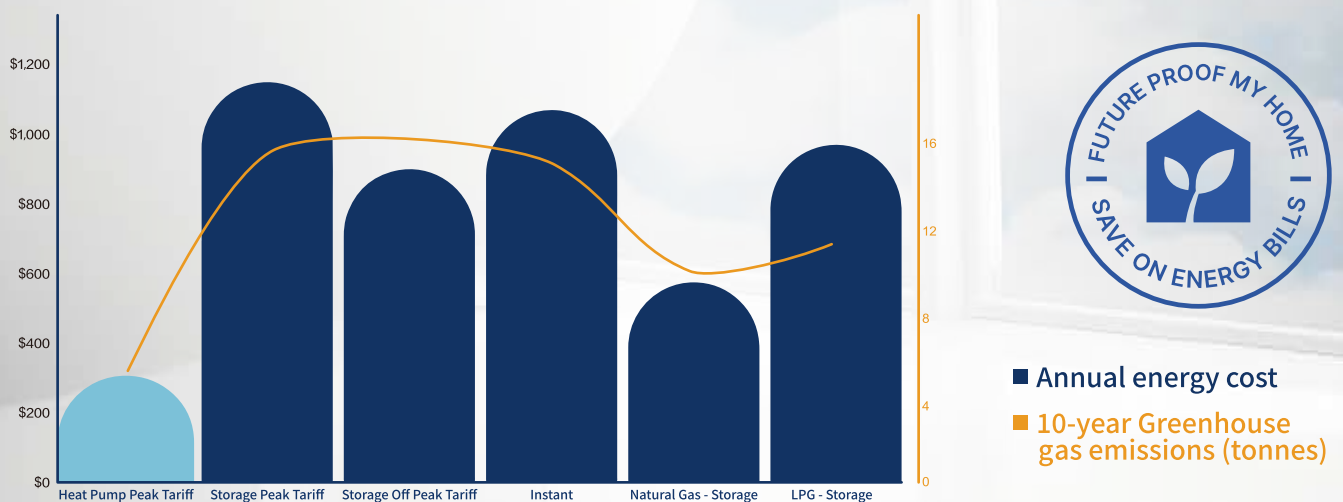

These calculations should be used as a guide only. Actual water heating energy costs will depend on a number of variables, including how you use hot water, energy tariffs, system efficiency and the flow rates etc.

Innovative Features

Wilson heat pumps adopt an inverter compressor, DC fan motor, electronic expansion valve and variable speed water pump to operate dynamically and achieve the optimal performance with greater energy savings.



Mitsubishi Inverter Compressor

- By utilizing Inverter compressor technology, the heat pump compressor varies its capacity therefore only uses the energy required.
- Minimises Heat Pump noise.

Variable Speed Fan Motor

- Running the fan at variable speeds minimizes noise and vibration.
- Allows maximum efficiency of the refrigeration system, minimising energy consumption whilst maximizing hot water production.



Stainless Steel Water Pump

- The heart of the system needs to be robust; a strong durable Stainless Steel variable water pump gives the best durability and minimal maintenance.

Double Layer Stainless Heat Exchanger

- Maximum protection from refrigerant entering the water system.
- High efficiency working with the refrigerant system to maximise hot water heating.



Electronic Expansion Valve

- Precise control of the refrigerant flow to maximise hot water production, minimizing energy consumption of the system.
- Working in conjunction with the micro processor to deliver high Coefficient of Performance.

Automated Air Exhaust Valve

- In built air exhaust valve to ensure continuous operation even if air enters the system.
- Minimises service requirements.



Efficiency Redefined

- Market Leading Energy Efficiency with a coefficient of performance (COP) of greater than 4.5¹.
- Utilises R-290 refrigerant, superior efficiency whilst minimising environmental impact.
- Delivers hot water up to 63°C*, ideal for larger homes and small commercial applications.
- Split system design allows greater installation flexibility and more installation options.
- More energy-saving with heat storage function.



¹ COP of 4.5 at 8.5°C wet bulb and 33°C inlet water temperature.

* Temperature on commercial model can reach 75°C, the higher temperature model does not attract rebates.

Natural Refrigerant R290

- The use of R290 is increasing due to its low environmental impact and excellent thermodynamic performance.
- It is non-toxic, with an ozone depletion potential (ODP) of 0 and a global warming potential (GWP) of 3. Its wide availability makes it a future-proof solution.

Refrigerant	R410A	R134a	R32	R290
ODP	0	0	0	0
GWP	2088	1430	675	3

Engineered for Peace of Mind



The fan operates at maximum efficiency without creating resistance and noise. Streamlined air flow design for greatest efficiency.



Meticulously designed to maximise performance yet maintain rigidity without causing unnecessary vibrations.



Compressor Insulation: A double-layer soundproof sponge greatly reduces the noise of the compressor.



Compressor designed to “float” on the base of the unit which greatly reduces vibrations.



Implementing multiple noise-reducing measures ensures a super quiet environment, with a sound pressure level as low as 39dB(A) at 1 metre.



39dB(A) at 1 metre

Smart Control

Wireless Connectivity Function

Wireless connectivity can allow the remote upgrade of the heat pump system software, improving product stability and simplifying the product upgrade service process.

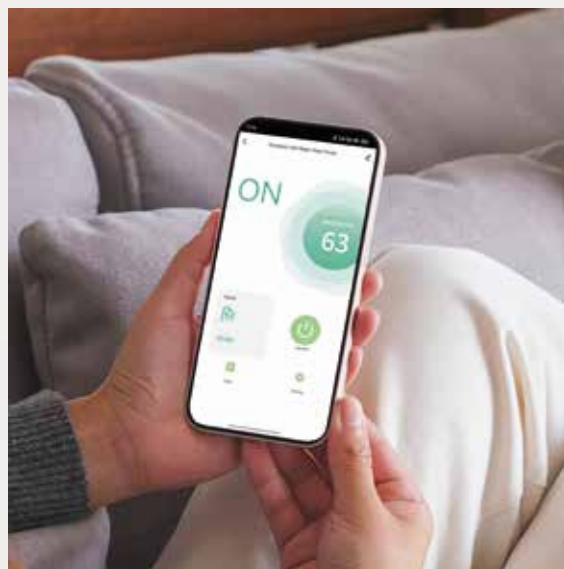

Intelligent Controller

- Simple Operation
- Mode for Selections



- Timer Setting
- Heat Storage Function

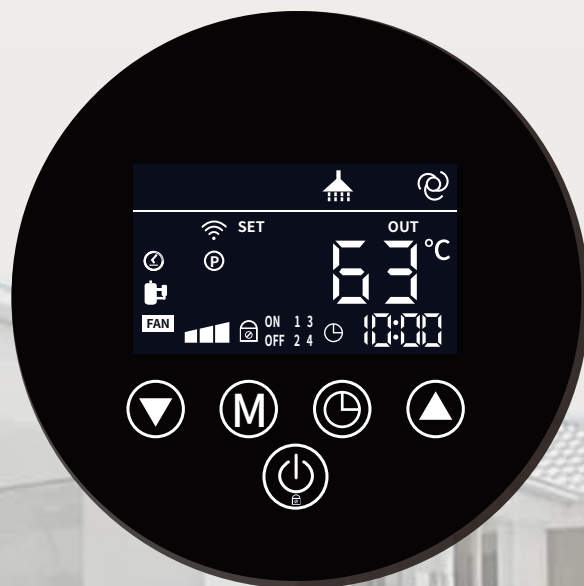

Sustainability and Peace of Mind

- Meticulously designed to operate safely in Australia's harshest conditions (from -25 °C to 45 °C)
- Backed by Wilson's 90 years of hot water experience
- Locally manufactured stainless-steel tank
- Attracts some of the highest Rebates in Australia
- Demonstrated efficiency
- Three operating functions:



Low noise



Performance



Automatic



Experience the New Generation of Hot Water

Upgrade to the Wilson Aqualux Heat Pump and future-proof your home against rising energy costs.

Enjoy hot water when you need it, with the assurance of quality, efficiency, and reliability.

Enjoy endless hot water whenever you want it with the peace of mind that your system is backed by Wilson's 90 years of manufacturing hot water systems in Australia.

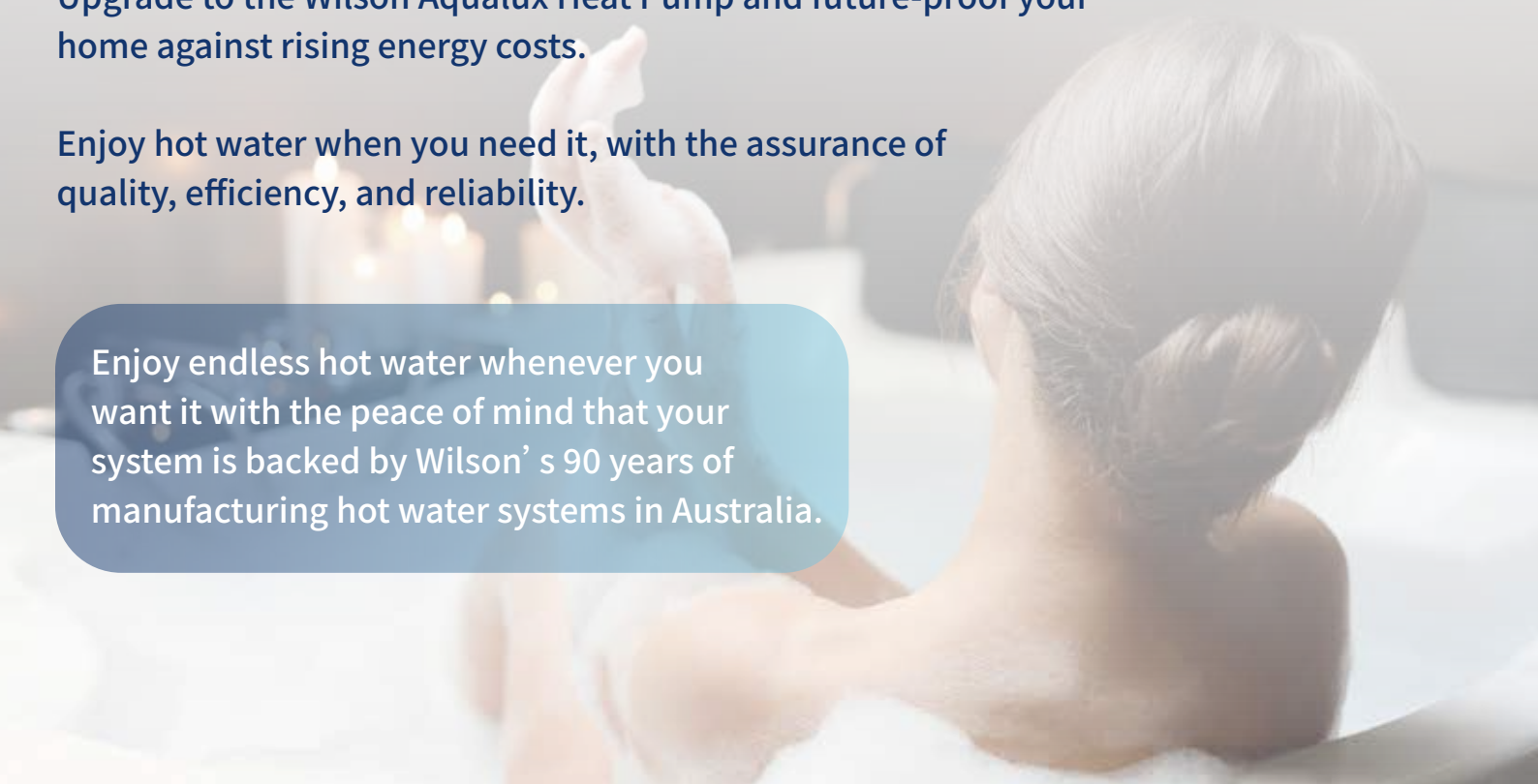

STC Rebate Zones

A Small-scale Technology Certificate (STC) is the equivalent of one megawatt hour of renewable energy generation.

The new Wilson Aqualux heat pump system attracts the STCs below, which can be traded for a cash rebate. Eligible households can also claim State rebates.

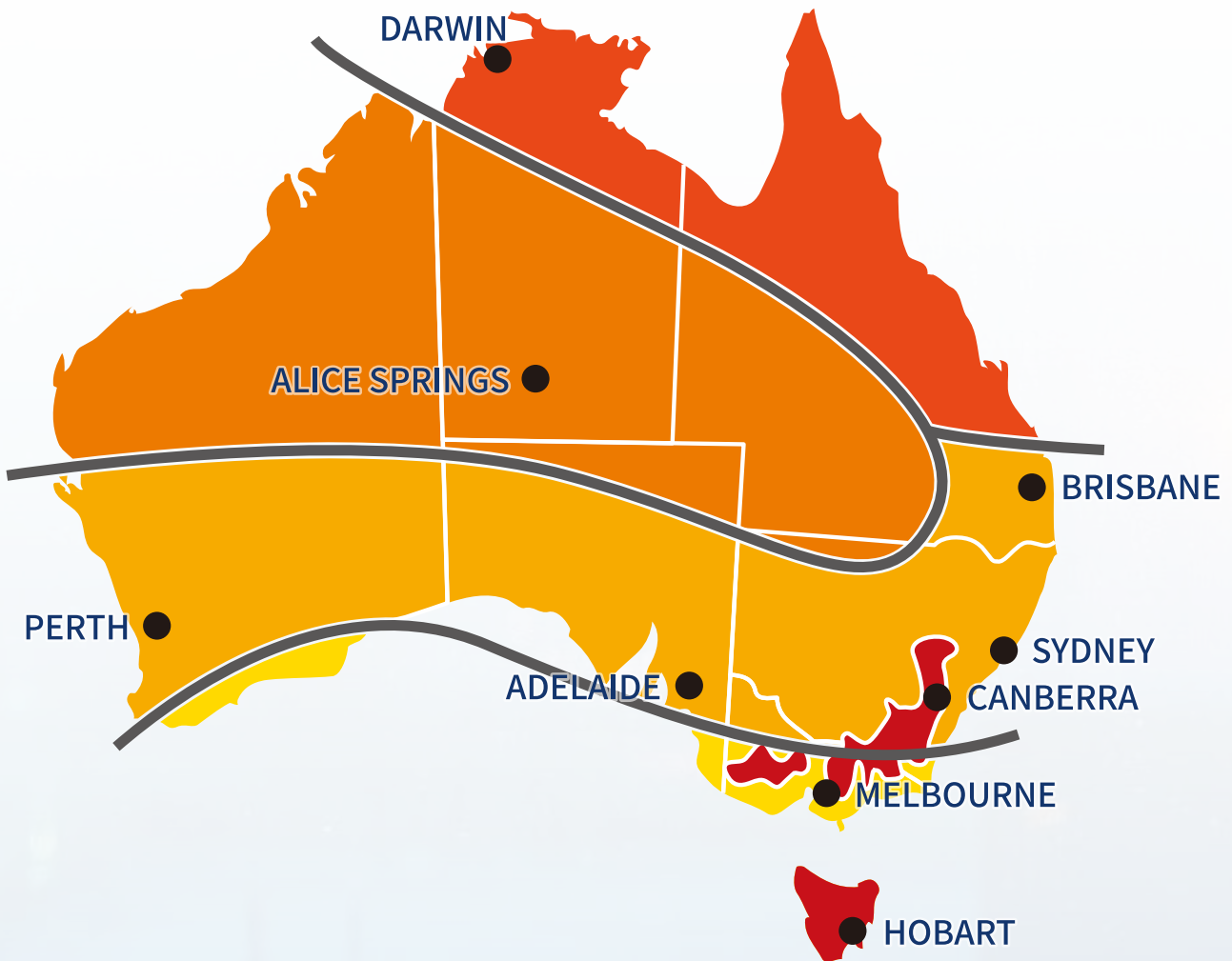

- ZONE 1
- ZONE 2
- ZONE 3
- ZONE 4
- ZONE 5

Model	STC Zone				
	FNQ	NT	Syd	Vic	Tas
	Zone 1	Zone 2	Zone 3	Zone 4	Zone 5
WHPS-160A	15	14	18	19	19
WHPS-250A	15	14	18	19	19
WHPS-315A	15	15	18	19	19

Based on 2025 values

Aqua Heat Pump Specification

Model No.	WHP-00315A	
[Hot Water] Ambient Temp. (DB/WB): 20°C/15°C, Water Temp. from 15°C to 55°C.		
Heating Capacity	kW	5.02
Power Input	kW	1.11
Current Input	A	4.92
COP	kW / kW	4.52
[Hot Water] Ambient Temp. (DB/WB): 7°C/6°C, Water Temp. from 9°C to 55°C.		
Heating Capacity	kW	4.20
Power Input	kW	1.16
Current Input	A	5.15
COP	kW / kW	3.62
Power Supply	V/Ph/Hz	220-240V~/50Hz
Max. Power Input	kW	1.32
Max. Running Current	A	7.00
Heating Operating Ambient Temp. Range	°C	-25~45
Rated Water Temperature	°C	60
Max. Outlet Water Temp.	°C	63
Rated Water Flow	m³/h	0.86
Hot Water Capacity	L/h	108
Water Pressure Drop	kPa	15
Compressor Brand	/	Mitsubishi
Fan Motor Type	/	DC Motor
Circulating Pump Brand	/	Shinhoo
Water Side Heat Exchanger	/	Double Layer Plate Heat Exchanger
Refrigerant Type	/	R290
Water Proof Class	/	IPX4
Water Pipe Connection	inch	G 1/2"
Sound Pressure Level at 1 Metre	dB(A)	39
Net Weight / Gross Weight	kg	60/75
Net Dimensions (L×W×H)	mm	1040×390×576

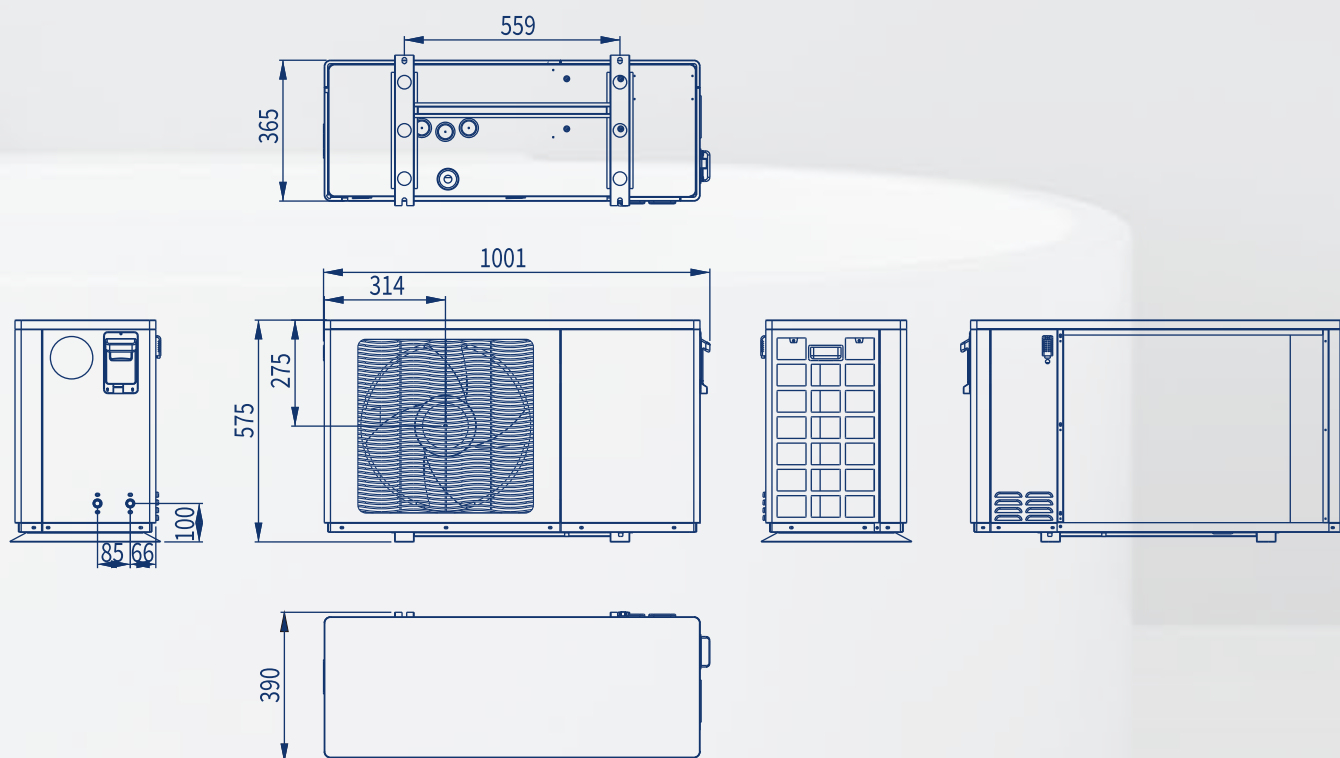

Storage Tank Specification

Tank Volume		315L	250L	160L
Height	mm	2008	1680	970
Hot Water Outlet & PTR Valve	mm	1803	1475	753
Sensor Port	mm	1317	989	249
Cold Water Inlet / Heat Pump Flow	mm	231	231	231
Diameter	mm	620	620	620
Weight (Empty)	kg	75	52	39
Inner Tank		Stainless Steel		
Water Connections and Settings				
Tank Relief Valve Setting (PTR valve)	kPa	700	700	700
Expansion Control Valve Setting (ECV)	kPa	700	700	700
Maximum Mains Pressure Setting				
With ECV	kPa	500	500	500
Inlet Water Operating Pressure	kPa	500	500	500
Adjustable Tempering Valve	kPa	1400	1400	1400
Hot and Cold Connection	inch	3/4" Female		
Colour		Shale Grey		
Country of Manufacture		Australia		
Warranty		10 year (excludes WA)		

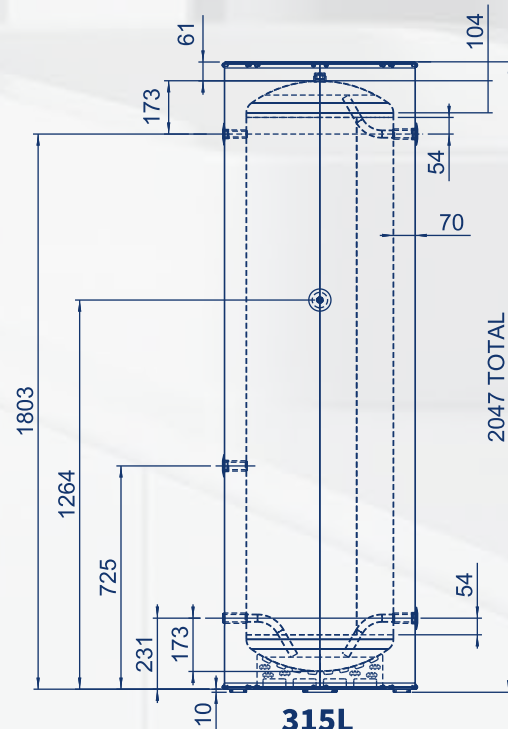
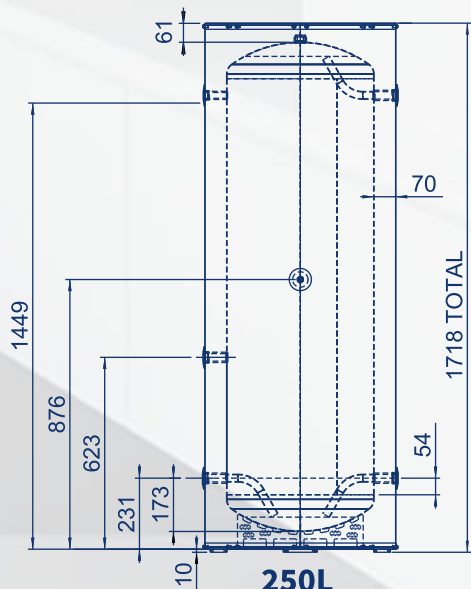
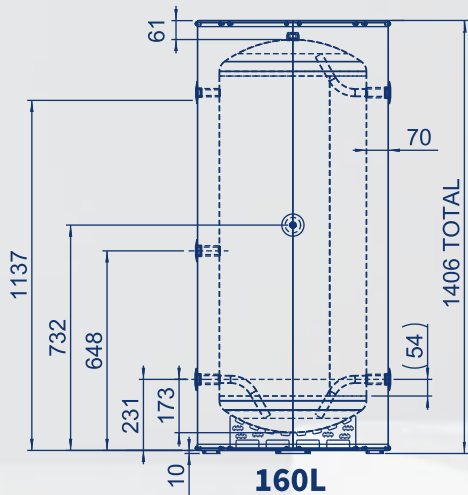

*Made in Australia

wilson

HEAT PUMPS



A new generation in hot water

CALL

1800 302 050

sales@wilsonheatpumps.com.au

www.wilsonheatpumps.com.au

wilson
HEAT PUMPS

59 Barry Street
Bayswater VIC 3153
Australia